



Digital Professional Bowl Cutters/Choppers

K50neo • K80neo



Market Leader in the Global Food Industry



K80neo + Unloader



K50neo



*Boost your productivity with more power and advanced features.
Designed in 2018, the most modern cutters on the market.*

K50neo: advantages at a glance



- Detachable 6-knife head and compensation rings for use with 3 knives.
- High-quality knives from BE-GW Steffens (Germany), adjustable to minimum distance to bowl.
- Optimized cavity design uses bottom of the stainless steel lid to also cut.
- Temperature sensor (°F/°C) located in the cutting cavity for precise measurement of mix during operation.
- Knife shaft designed with dynamic 3D modelling to achieve further reduction of vibrations.

- IP65 watertight electric cabinet.
- Maintenance free bearings with 2 year warranty.
- Polished surfaces, without corners, with $\text{C}\epsilon$ radius to facilitate cleaning and comply with the highest hygienic requirements.
- Hygienic labyrinth in the knife head to prevent meat dough from entering the shaft / bearings.
- Electric heating device to avoid condensation inside the machine.
- Bottom of machine closed with labyrinthine breathing slots.
- Removable lid/bowl friction band to facilitate cleaning.

- Machine frame, bowl and all bolts & screws 100% stainless steel AISI304.
- Very solid construction. Strong machine frame.
- Solid bowl made of robust stainless steel cast, with liquid drain plug.
- Adjustable NGI Denmark feet, non-slip and vibration absorbing.



- Bowl capacity K50npp: up to ± 37 kg (± 82 lbs) soft meat or ± 25 kg (± 55 lbs) tough meat. K50nb: $\pm 32/\pm 20$ kg ($\pm 71/\pm 44$ lbs).
- Motorized stainless steel knife lid for effortless lifting and lowering.
- Noise protection plastic cover with $\text{C}\epsilon$ safety clearance of the knife speed when opening and returning to the previous speed when closing.

- Control panel with large 7" digital touch screen and 6 membrane pushbuttons.
- Variable high cutting speed from 1.000 to 4.000 rpm.
- 4 preselectable knife speeds: 1.000, 2.000, 3.000 and 4.000 rpm.
- Variable bowl speed from 6 to 18 rpm, 4 preselectable speeds.
- Slow mixing speed variable from 50 to 200 rpm, forward & reverse.
- 4 preselectable speeds: 50, 100, 150 and 200 rpm.
- Variable mixing bowl speed from 6 to 10 rpm.

- High power to cut compact and tough meat.
 - K50nb: 22 HP / 16,5 kW
 - K50npp (with PowerPlus option): 32 HP / 23,5 kW.
- High energy efficiency class IE3 globally, with high performance ABB motors and VDF electronic frequency converters.
- Smooth starts and stops of knives and bowl due to next generation electronic frequency converters.
- Automatic electronic knife safety brake.
- Thermal protection on all motors.
- Standard voltage 400/380 V, other voltages available.

K80neo: advantages at a glance



- Detachable 6-knife head and compensation rings for use with 3 knives.
- High-quality knives from BE-GW Steffens (Germany), adjustable to minimum distance to bowl.
- Optimized cavity design uses bottom of the stainless steel lid to also cut.
- Temperature sensor (°F/°C) located in the cutting cavity for precise measurement of mix during operation.
- Knife shaft designed with dynamic 3D modelling to achieve further reduction of vibrations.

- Bowl capacity K80npp: up to ±60 kg (±132 lbs) soft meat or ±40 kg (±88 lbs) tough meat. K80nb: ±52/±32 kg (±115/±70 lbs).
- Motorized stainless steel knife lid for effortless lifting and lowering.
- Noise protection plastic cover with CE safety clearance of the knife speed when opening and returning to the previous speed when closing.
- Unloader extracting arm with motorized disc (optional).

- Machine frame, bowl and all bolts & screws 100% stainless steel AISI304.
- Very solid construction. Strong machine frame.
- Solid bowl made of robust stainless steel cast, with liquid drain plug.
- Adjustable NGI Denmark feet, non-slip and vibration absorbing.

- IP65 watertight electric cabinet.
- Maintenance free bearings with 2 year warranty.
- Polished surfaces, without corners, with CE radius to facilitate cleaning and comply with the highest hygienic requirements.
- Hygienic labyrinth in the knife head to prevent meat dough from entering the shaft / bearings.
- Electric heating device to avoid condensation inside the machine.
- Bottom of machine closed with labyrinthine breathing slots.
- Removable lid/bowl friction band to facilitate cleaning.

- Control panel with large 7" digital touch screen and 6 membrane pushbuttons.
- Variable high cutting speed from 1.000 to 4.000 rpm.
- 4 preselectable knife speeds: 1.000, 2.000, 3.000 and 4.000 rpm.
- Variable bowl speed from 6 to 18 rpm, 4 preselectable speeds.
- Slow mixing speed variable from 50 to 200 rpm, forward & reverse.
- 4 preselectable speeds: 50, 100, 150 and 200 rpm.
- Variable mixing bowl speed from 6 to 10 rpm.
- High power to cut compact and tough meat.
 - K80nb: 32 HP / 23,5 kW
 - K80npp (with PowerPlus option): 42 HP / 31,5 kW.
- High energy efficiency class IE3 globally, with high performance ABB motors and VDF electronic frequency converters.
- Smooth starts and stops of knives and bowl due to next generation electronic frequency converters.
- Automatic electronic knife safety brake.
- Thermal protection on all motors.
- Standard voltage 400/380 V, other voltages available.

Standard equipment



Knife Head with **6 standard knives**
BE-GW Steffens (Germany).



2 compensation rings for use with
3 knives.



Digital display to control and program
all functionalities of the cutter.



Stainless steel **motorized knife lid**
for effortless lifting and lowering.



Noise protection cover with automatic
decrease of knife speed.



Very solid construction.
Large openings to access the interior.

Standard equipment

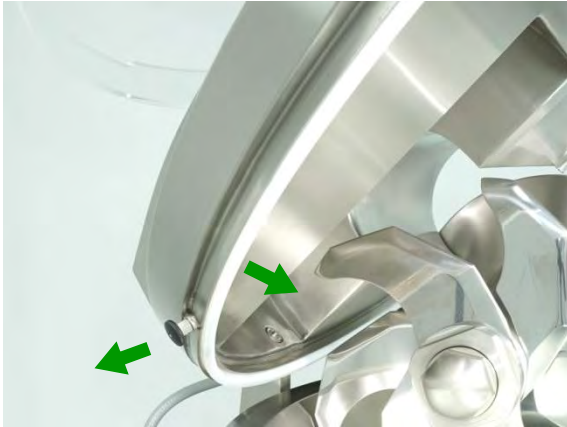

Removeable lid/bowl friction band to facilitate cleaning.



Smooth polished surfaces, no corners or screws, with $\text{C}\epsilon$ radius for easy cleaning.



Bowl with drain plug with automatic positioning.

Standart power:
K50nb: 22.5 HP / 16,5 kW
K80nb: 32.0 HP / 23,5 kW



Powerful ABB knife motors to process compact and dogged meat.

PowerPlus Option
K50npp: 32.0 HP / 23,5 kW
K80npp: 42.0 HP / 31,5 kW



Extra power (PowerPlus) for heavy applications.



Option for K80neo

Unloader extracting arm with motorized disc for easy and comfortable unloading.

Outstanding features



The **Talsa K50neo and K80neo** bowl cutters are designed for the production of hash of all kinds, for butcher's shops and small industrial meat processors. They are also suitable for a wide range of poultry, fish, pastry or vegetarian products, processed cheese and many commodities in the food processing industry.

The K50neo and the K80neo cut, mix and emulsify all types of food products, from thick to very fine textures. They are simple to use, have an automated control system and are cleaned and maintained with ease.



Innovative design

R&D project on vibration and sound reduction in cooperation with the Polytechnic University of Valencia, Mechanical Engineering Research Centre:

- ✓ Fully 3D computer modelling designed.
- ✓ Vibration reduction on the knife shaft.
- ✓ Reduction of noise and vibration in the chassis.
- ✓ Silent drive transmission.

Talsa Control

- ✓ Modern 7-inch touch screen.
- ✓ 6 membrane buttons for the most used functions.
- ✓ Digital display indicating gear, blade speed, temperature, turns, elapsed time, current time.
- ✓ Automatic stop: time elapsed, temperature and/or turns of the bowl.
- ✓ Display maintenance and service intervals.

Optional:

- ✓ Interactive recipe guide.
- ✓ User administration.
- ✓ Data recording.
- ✓ Production plan.

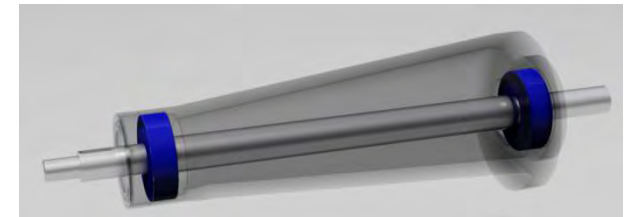

Technical specifications



		K50neo	K80neo
Bowl capacity		50 liters (13 Gallon)	80 liters (21 Gallon)
Approximate batch size	soft mix	± 7-37 kg (± 15-82 lbs)	± 15-60 kg (± 33-132 lbs)
	tough mix	± 7-25 kg (± 15-55 lbs)	± 15-40 kg (± 33-88 lbs)
Machine power	Kxxnb	standard 16,5 kW (22.5 HP)	23,5 kW (32.0 HP)
	Kxxnpp	PowerPlus 23,5 kW (32.0 HP)	31,5 kW (42.0 HP)
Knife motor power	standard	15,0 kW (20.5 HP)	22,0 kW (30.0 HP)
	PowerPlus	22,0 kW (30.0 HP)	30,0 kW (40.0 HP)
Bowl motor power		1,5 kW (2.0 HP)	1,5 kW (2.0 HP)
Hydraulic unloading disc motor power		-	0,4 kW (0.5 HP)
Max. consumption, standard	380/400 V	31,8 A	41,3 A
	220/230 V	52,6 A	72,9 A
Max. consumption, PowerPlus	380/400 V	41,3 A	60,0 A
	220/230 V	72,9 A	107 A
Knife speed cutting	variable	1.000 to 4.000 rpm	
	preselectable	1.000/2.000/3.000/4.000 rpm	
Linear knife speed	at 4.000 rpm	up to 75 m/s	up to 87 m/s
Bowl speed cutting		6/10/14/18 rpm	
Knife speed mixing	variable	50 to 200 rpm	
	preselectable	50/100/150/200 rpm	
Bowl speed mixing		6/10 rpm	
Speed of unloader disc		130 rpm @ 50 Hz (156 rpm @ 60 Hz)	
Net weight approx.		± 700 kg (1,540 lbs)	± 1.100 kg (2,425 lbs)
Sound pressure level at 1m		± 74 dB(A)	± 75 dB(A)
Operating temperature		+5° to +40° C (40° to 105° F)	
Recommended relative humidity level		20 to 90 %	

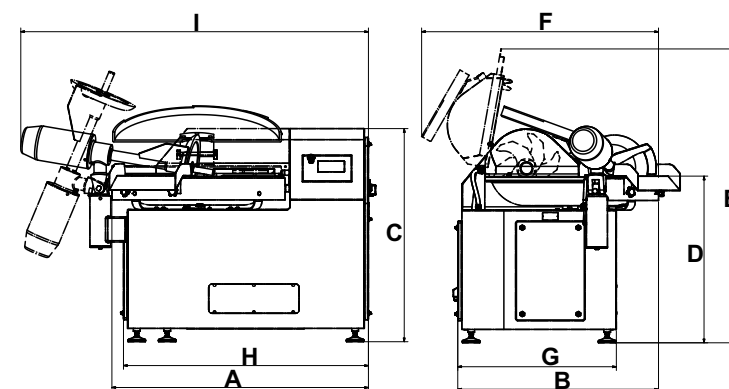

Dimensions cm (inch)	K50neo	K80eon
A	125 (50")	154 (61")
B	96 (38")	120 (48")
C	120 (48")	128 (51")
D	97 (38")	100 (40")
E	160 (63")	175 (69")
F	116 (46")	141 (56")
G	76 (30")	95 (38")
H	119 (47")	147 (58")
I	-	208 (82")
Packaging	144x114x140 (57x45x55")	164x134x155 (65x53x61")
Volume	2,3 m ³	3,4 m ³

Important advice: always choose large bowl cutter capacity and power, to allow the future growth of production.
Available Talsa capacities: 15, 30, 50, 80, 120 and 200 liters.

TALSA, Tradition and Innovation:

40 years producing cutters.

120 years of industrial experience in machinery.

Sales and distributors in more than 60 countries.



Four generations of the Belloch family have succeeded in making what began as a small mechanical workshop founded in 1900 to serve the electrical industry, more than 100 years later an efficient industrial structure of 6000m² where attention, illusion and constant improvement is paid to every detail of our machines.

In this catalog we offer you the best of our knowledge and experience and the most modern and innovative machines, newly designed with advanced 3D software technology and R&D support from the European Union.

Thank you for your confidence.

Our product range:

Cutters/Choppers • Fillers/Stuffers • Mixers • Minced/Grinders • Cookers/Kettles



Talsabell s.a.
Valencia - Spain
www.talsanet.com



Your authorized TALSA dealer:

Dimensions and illustrations are not binding. We reserve the right to make changes.