



# BASELINE P Series

**Chamber Machines**

P 500

P 600

P 605

P 650

P 700

## The BASELINE range – professional from top to bottom

Successful and high quality vacuum packing is simple with BASELINE chamber machines, because every BASELINE machine is a genuine MULTIVAC. This means that a long lifespan, a high level of reliability and the best service are guaranteed.

Even inexperienced personnel are able to pack reliably and efficiently with a BASELINE machine. BASELINE chamber machines are therefore the ideal vacuum packing solution for large pieces and large batches, as needed in meat packing plants, cheese dairies, etc. It can also be used for a wide range of consumer and industrial products.

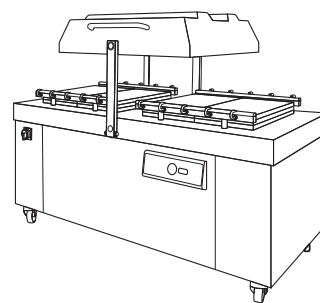
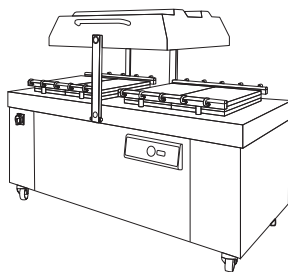
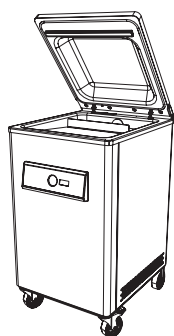

**BASELINE product range**

Type	P 400	P 500	P 600
Design	Free-standing machine	Double chamber machine	Double chamber machine
Usable volume	420 x 425 x 170 mm	500 x 400 x 160 mm	600 x 500 x 160 mm
Pump output	60 m <sup>3</sup> /h	60 m <sup>3</sup> /h	60 m <sup>3</sup> /h

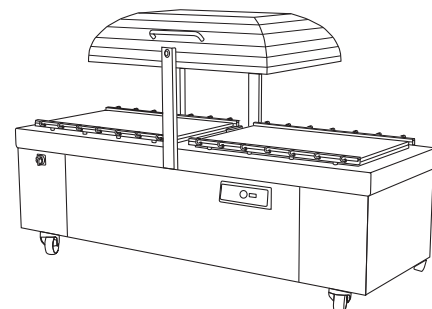
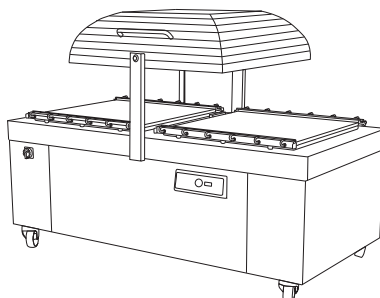
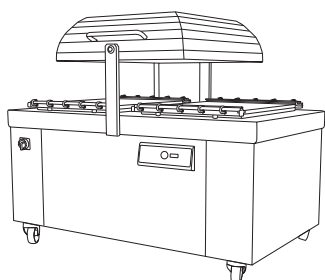

Type	P 605	P 650	P 700
Design	Double chamber machine	Double chamber machine	Double chamber machine
Usable volume	600 x 745 x 200 mm	850 x 850 x 250 mm	1,100 x 700 x 250 mm
Pump output	150 m <sup>3</sup> /h	300 m <sup>3</sup> /h	300 m <sup>3</sup> /h

All BASELINE double chamber machines are available if required with a gas flushing unit.



## BASELINE P500

**Double chamber machine**  
500 x 400 x 160 mm



## BASELINE P600

**Double chamber machine**  
600 x 500 x 160 mm



## BASELINE P605

**Double chamber machine**

600 x 745 x 200 mm



## BASELINE P650

**Double chamber machine**

850 x 850 x 250 mm

## BASELINE P700

**Double chamber machine**

1100 x 700 x 250 mm

## Quality and equipment for high demands

### **Sealing systems**

MULTIVAC packaging solutions are guaranteed to meet the highest quality requirements. Our proven sealing systems ensure film pouches are sealed with a permanent seal and they contribute to achieving maximum pack security.



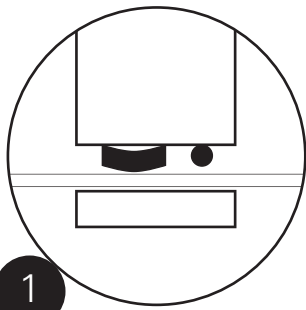

**Double-seam sever sealing**

The sealing bar is equipped with a 3 mm wide heating band and a separate severing wire. This enables the excess length of the film pouch to be torn off easily after sealing. This results in a clean-looking and visually attractive pack.

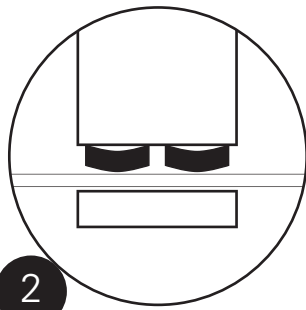

**Double-seam sealing**

Two seal seams, each 3 mm wide, offer additional security. This is particularly useful when packing products with liquid, or if the sealing surfaces are easily contaminated.

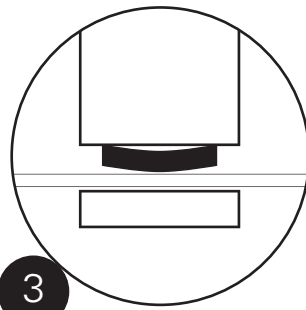

**Single-seam sealing**

The film pouch is sealed securely and reliably with a 6 mm wide seal seam.

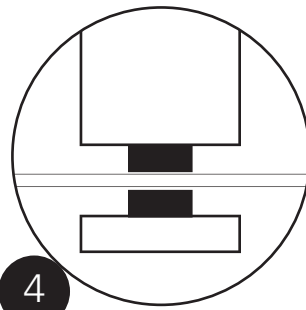

**Single-seam sealing on top and bottom**

The simultaneous heat effect from the top and bottom enables thick or multi-layer film pouches to be sealed with a permanent seal.

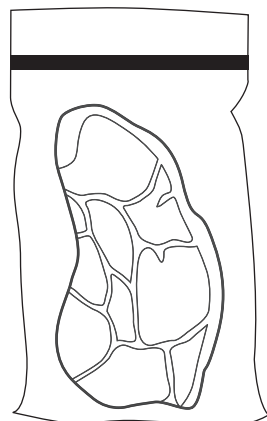
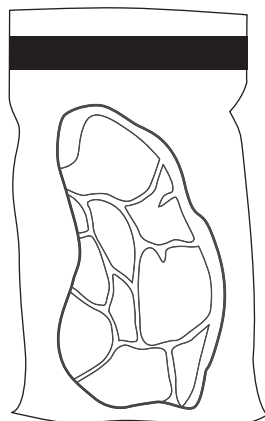
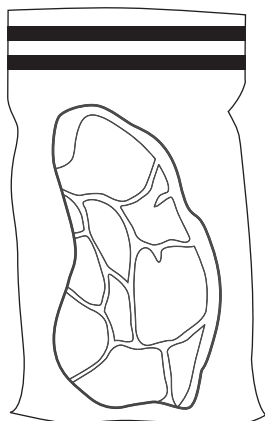
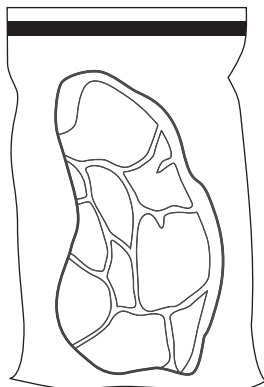

# The BASELINE – easy to operate

## **MCB 01 (time-controlled)**

The intuitive BASELINE MCB 01 machine control makes packaging easy even for inexperienced personnel. The times for evacuation, gas flushing and sealing are entered on the clearly arranged membrane keyboard and can be read on the backlit LCD display. They can be stored in one of the three program memories at the touch of a button. The evacuation and gas flushing processes can be stopped at any time with the quick-stop button; the pack is then immediately sealed. The vacuum gauge accurately displays the current pressure in the chamber throughout the entire packaging procedure.

## **MC 06 (pressure-controlled)**

With the MC 06 machine control, the pressure in the chamber is directly measured using a precise vacuum sensor and taken into account in the process sequence. This means, irrespective of the size and nature of the packaged goods, the values set in the machine control for vacuum and gas flushing are reliably achieved. In addition to a consistently high packaging quality, the user's work is simplified and the rate of packaging is accelerated. All the process stages are clearly shown on the LCD display. In the recipe memory, 29 different programs for a variety of products can be stored and called up at the touch of a button. In addition, the MC 06 has over 18 operating languages available. An automatic program permits even inexperienced operators to achieve perfect packaging results: when an ideal vacuum is achieved, the evacuation process is automatically terminated and the next step in the process started.



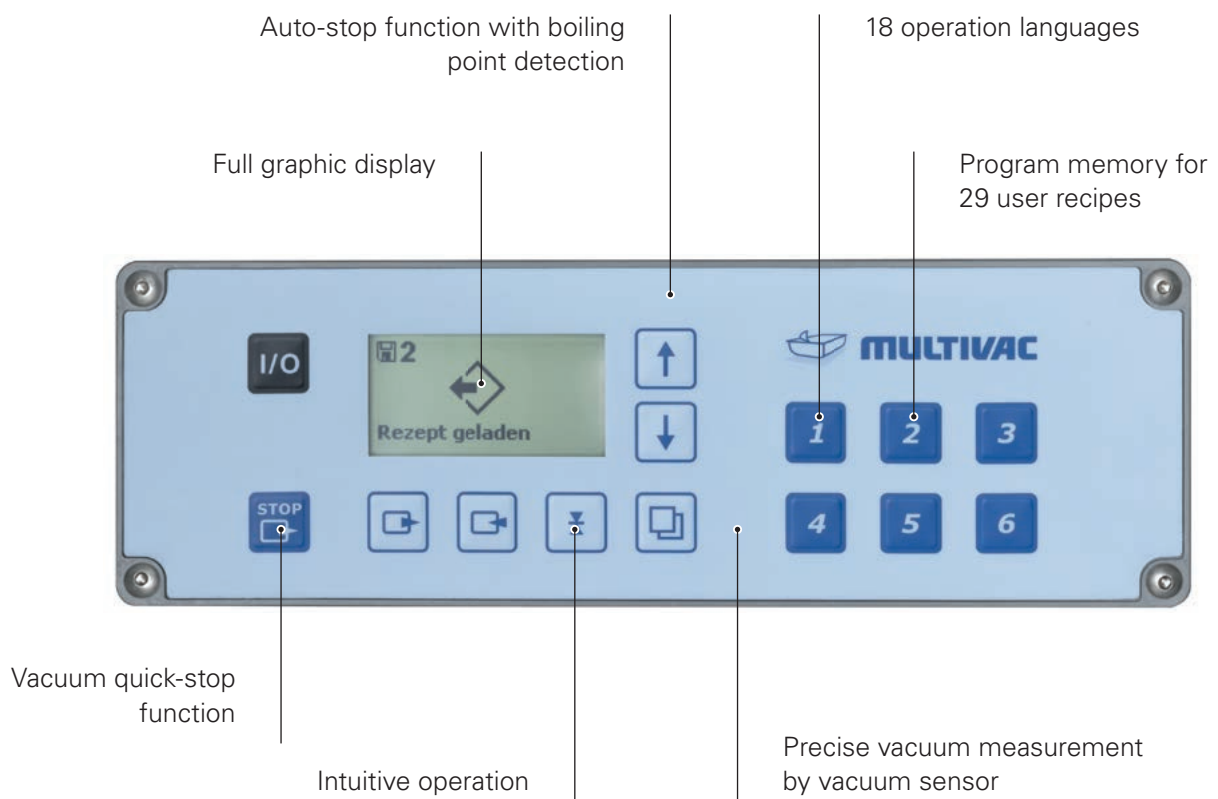
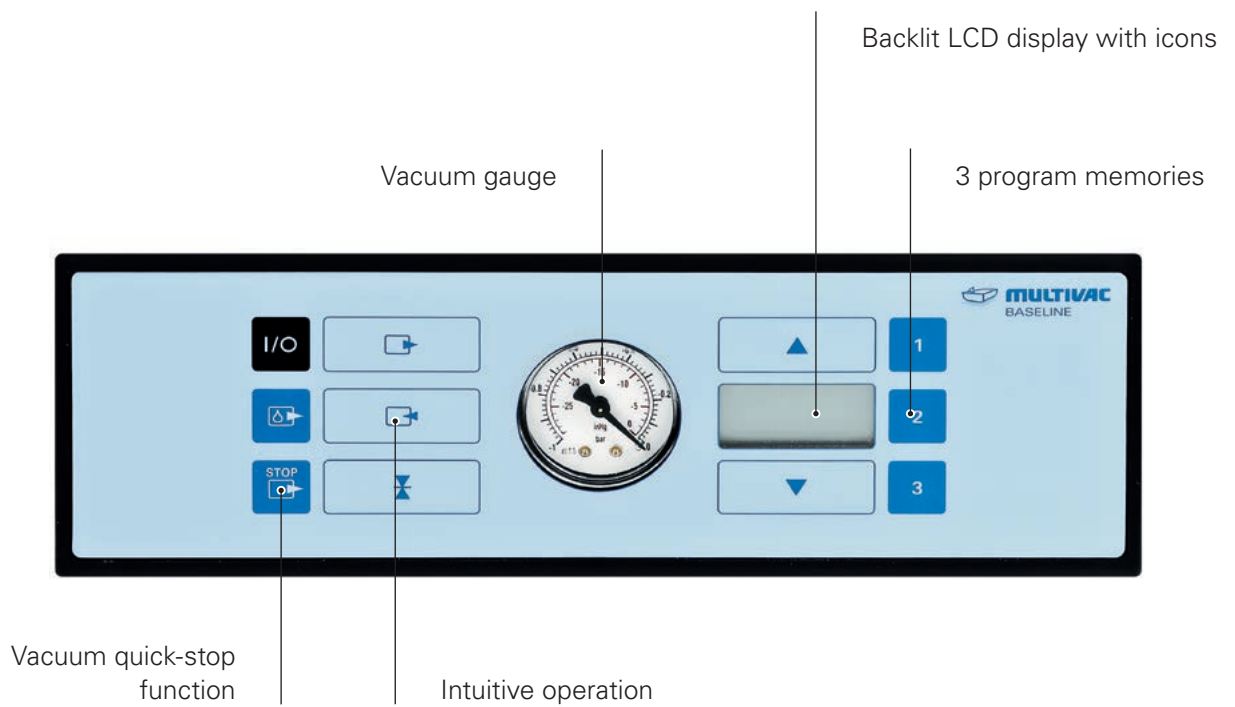

# Technical specifications

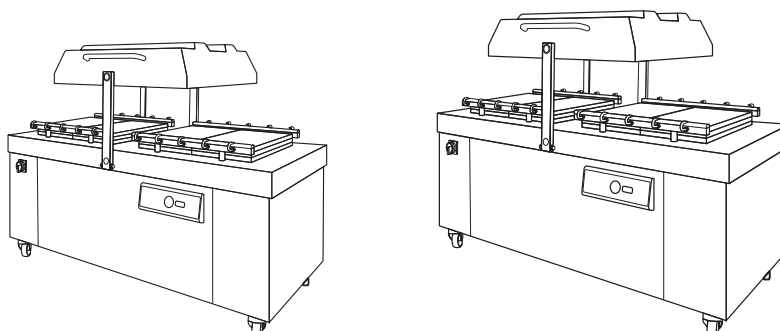

Type	P 500	P 600
Design	Double chamber machine	Double chamber machine
Chamber dimensions (useable) (W x D x H) in mm	500 x 400 x 160	600 x 500 x 160
Machine dimensions (W x D x H) in mm	1,500 x 670 x 1,050 (1,350 opened)	1,635 x 770 x 1,050 (1,350 opened)
Approx. weight in kg	350	400
Pump capacity in m <sup>3</sup> /h	• 60   o 100, 150	• 60   o 100, 150
Sealing	Double-seam sever sealing 1 x 3 mm, 1 x 1 mm	Double-seam sever sealing 1 x 3 mm, 1 x 1 mm
Sealing bar	insertable	insertable
Usable sealing length in mm	500	600
Machine control	MCB 01	MCB 01
Electrical connection values	3 x 400 V, 50 Hz 3 x 220 V, 60 Hz	3 x 400 V, 50 Hz 3 x 220 V, 60 Hz

## Options

Type	P 500	P 600
Gas flushing system	o	o
MC 06 machine control including vacuum sensor	o	o
Alternative chamber lid height in mm	110	110
Mobile machine on rollers	o	o

## Sealing types

Double-seam sever sealing	•	•
Single-seam sealing	o	o
Double-seam sealing	o	o
Single-seam sealing top/ bottom	o	o

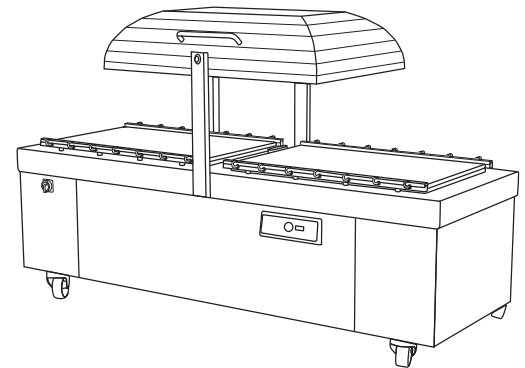
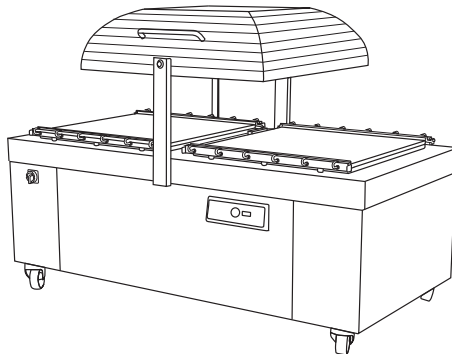
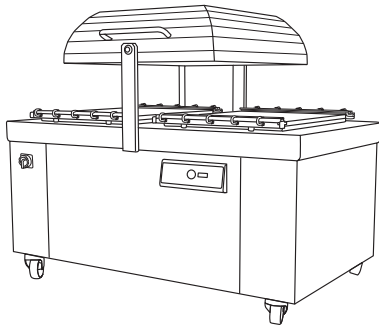

P 605	P 650	P 700
Double chamber machine	Double chamber machine	Double chamber machine
600 x 745 x 200	850 x 850 x 250	1,100 x 700 x 250
1,635 x 1,010 x 1,100 (1,400 opened)	2,150 x 1,150 x 1,145 (1,550 opened)	2,600 x 1,000 x 1,145 (1,600 opened)
650	800	850
• 100   o 150, 160, 200, 250, 300	• 160   o 200, 250, 300	• 160   o 200, 250, 300
Double-seam sever sealing 1 x 3 mm, 1 x 1 mm	Double-seam sever sealing 1 x 3 mm, 1 x 1 mm	Double-seam sever sealing 1 x 3 mm, 1 x 1 mm
insertable	insertable	insertable
600	850	1,100
MCB 01	MCB 01	MCB 01
3 x 400 V, 50 Hz 3 x 220 V, 60 Hz	3 x 400 V, 50 Hz 3 x 220 V, 60 Hz	3 x 400 V, 50 Hz 3 x 220 V, 60 Hz

P 605	P 650	P 700
o	o	o
o	o	o
-	-	-
o	o	o
•	•	•
o	o	o
o	o	o
o	o	o



MULTIVAC  
Sepp Haggenmüller SE & Co. KG  
Bahnhofstr. 4  
87787 Wolfertschwenden  
Germany

[www.multivac.com](http://www.multivac.com)

© MULTIVAC - 01/2017 · Subject to technical changes in line with product development  
MULTIVAC and BASELINE are registered trademarks of MULTIVAC Sepp Haggenmüller SE & Co. KG